

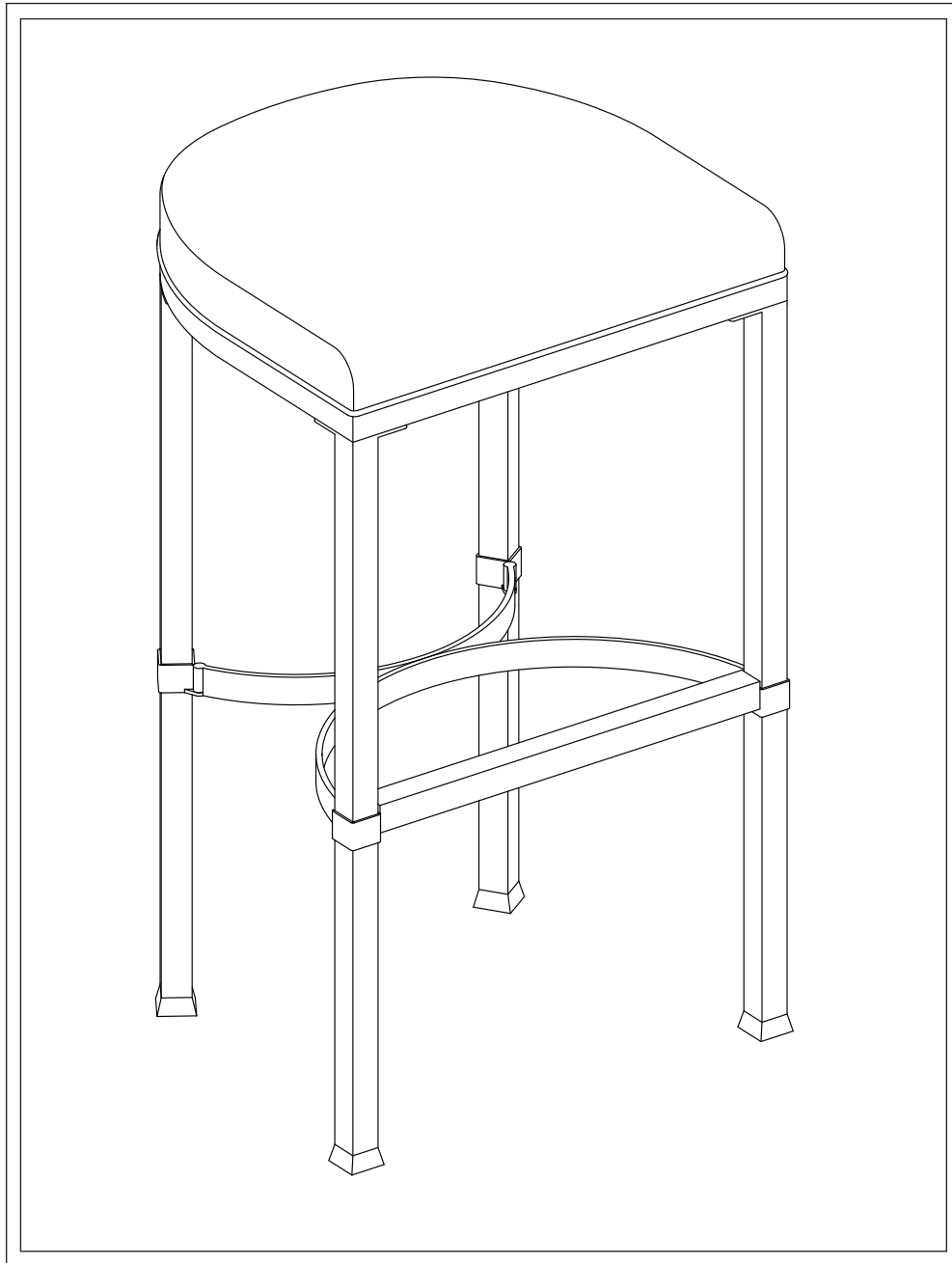

PRODUCT NAME: Sloan Bar Stool

ITEM NUMBER: 176397

DIMENSIONS OF ITEM ASSEMBLED: 30"H x 17"W x 16"D

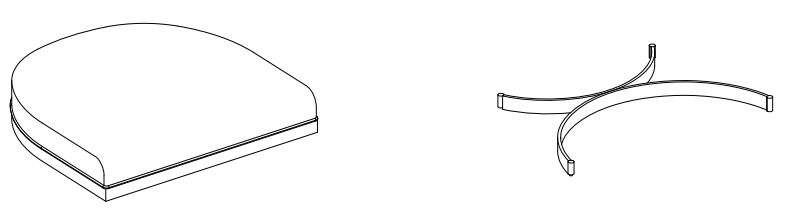
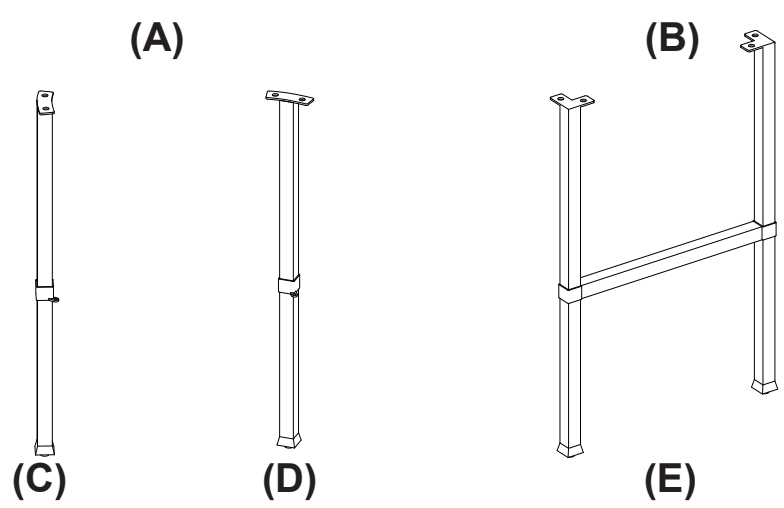

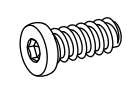
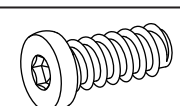
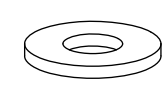
Ltr.	Qty.	Description.	Components
A	1	Seat	 
B	1	Stretcher	
C	1	Left Back Leg	
D	1	Right Back Leg	
E	1	Front Leg	

Ltr.	Qty.	Description.	Hardware Included
F	4	Allen Bolts	 Ø3/16"x1/2"
G	8	Allen Bolts	 Ø1/4"x3/4"
H	8	Flat Washer	
I	1	Allen Key	

STEP 1: Assemble Stretcher (B) to Front Leg (E), Left Back Leg (C) and Right Back Leg (D) using Allen Bolt (F) and Allen Key (I).

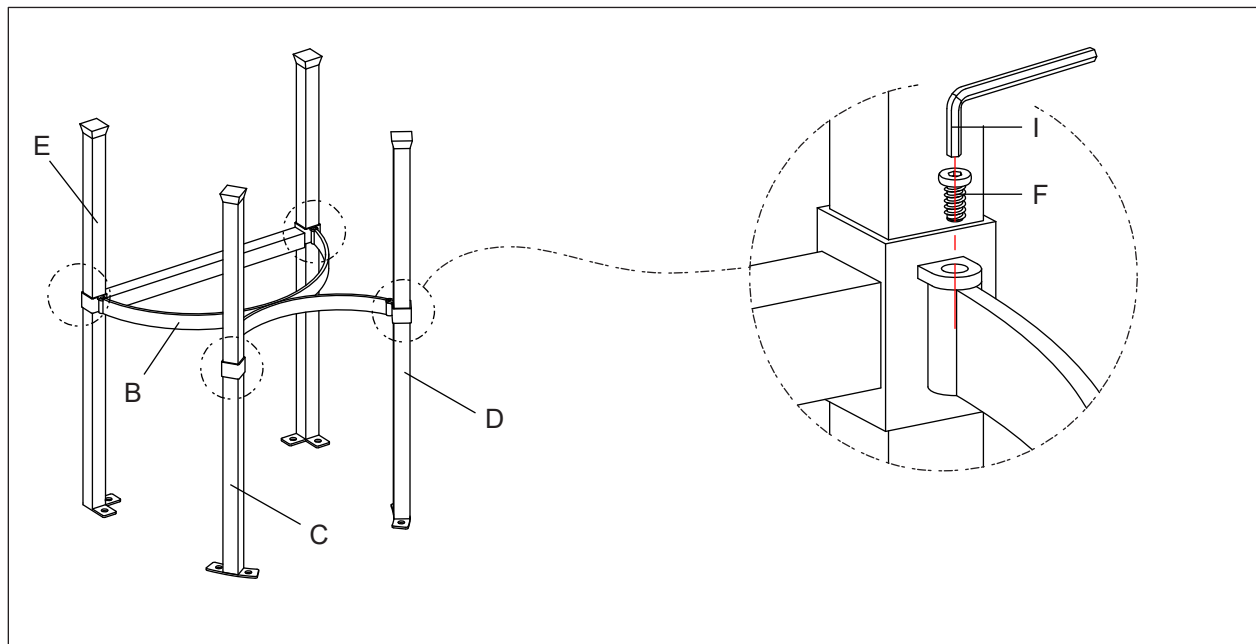

STEP 2: Assemble Seat (A) to the Legs using Allen Bolts (G), Flat Washer (H) and Allen Key (I).

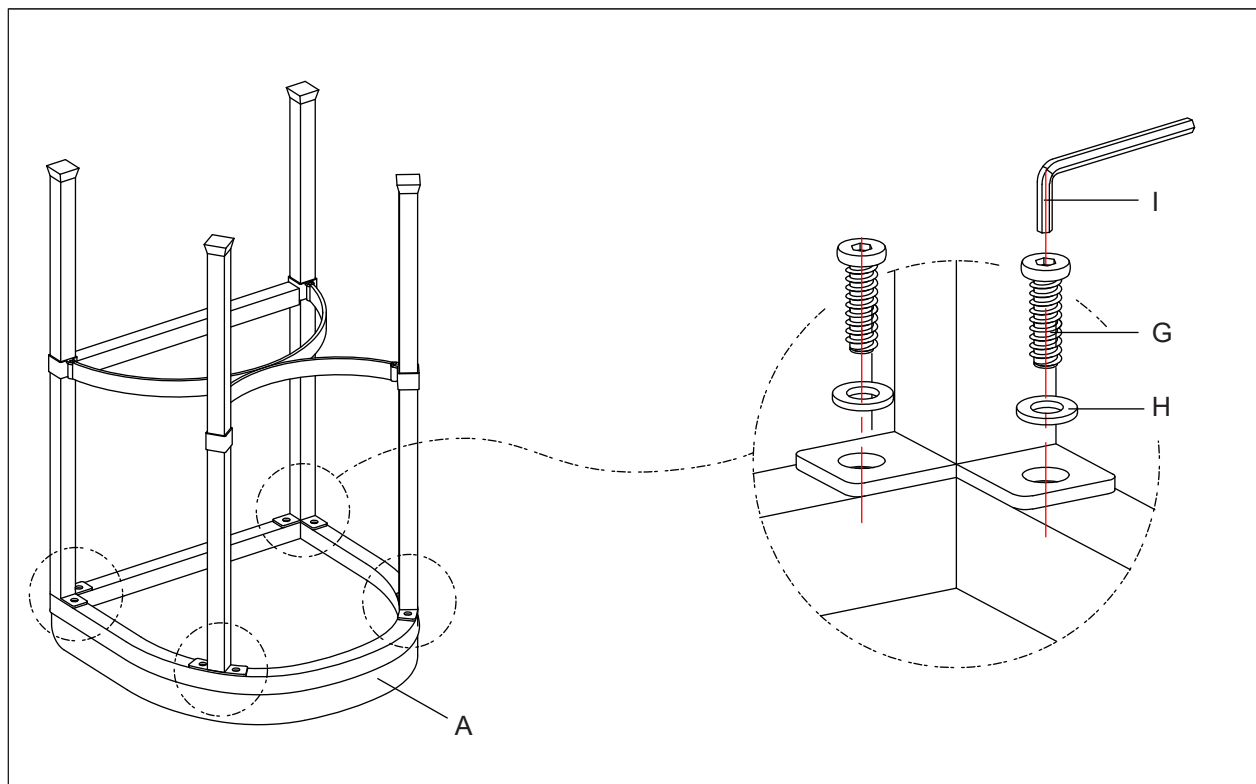

Cleaning & Care:

Wipe with damp cloth and mild detergent. Avoid the use of any abrasive cleaning agents as this may mar the surface. Always lift the unit when moving and avoid dragging to prevent loosening or damaging frame structure.

